

**SPECIFICATION**

50Hz

Rev. G

<b>PUMP</b>		
Liquid Handled	Type of liquid	Clear water (Clean water for MS version)
	Max temperature [°C]	50
	Max solids size [mm]	10
Maximum immersion	[m]	2 (with power cable length 5 m) 5 (with power cable length 10 m)
Construction	Impeller	Semi-open centrifugal type
	Shaft seal type	Oil lubricated mechanical seal (pump side) + lip seal (motor side)
	Bearing	Sealed ball bearing
Pipe Connection	Suction	Strainer
	Discharge nozzle [inch]	G1¼": UNI ISO 228
Material	Pump casing	AISI 304
	Impeller	PPE + PS Glass fiber reinforced
	Shaft seal	Mechanical seal: Ceramic/Carbon/NBR Lip seal: NBR
	Casing cover	AISI 304
	Shaft	AISI 303 + AISI 303 ceramic coated shaft sleeve
	Lubricating liquid	White mineral oil: Esso Marcol 152
Applicable standard of test		ISO 9906:2012 - Grade 3B

<b>MOTOR</b>		
Type		Submersible dry type Single Phase
No. of Poles		2
Rotation speed	[min <sup>-1</sup> ]	≈2800
Insulation Class		F
Protection degree		IP 68
Power rating	[kW]	0.25
	[HP]	0.33
Frequency	[Hz]	50
Voltage	[V]	230 ±10%
Capacitor		Built in
Over load protection		Built in
Casing material		AISI 304
Switch	float	MA version (no maintenance required)
	magnetic	MS version (maintenance required)
Float/magnetic switch cable	material	H07RN-F
	size	3G1
Power cable	length [m]	5 (only for internal usage); 10
	material	H05RN-F
	size	3G0.75
Cable entry		Cable Gland

PERFORMANCE RANGE

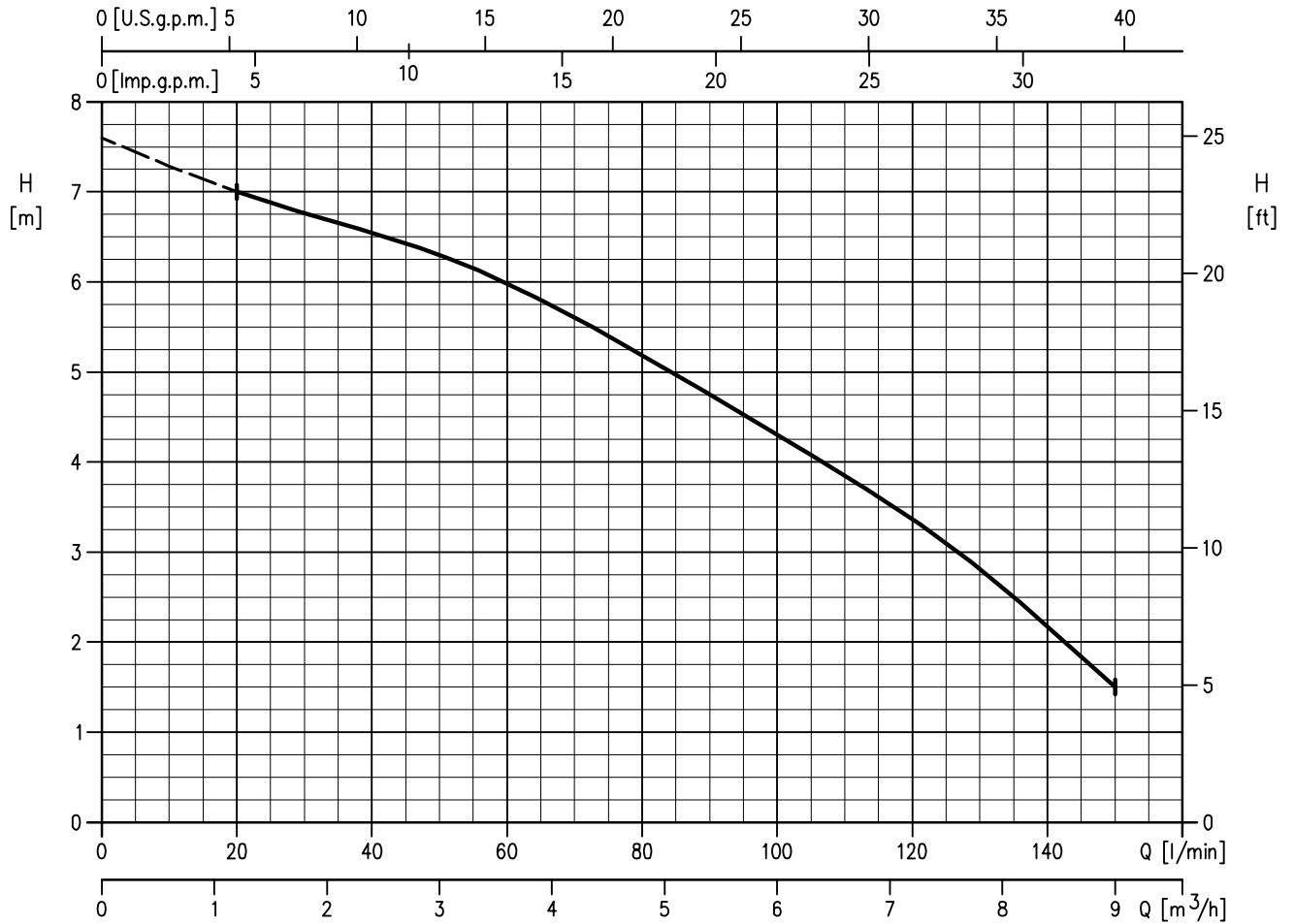

SELECTION CHART

Pump Type	Power		Q=Capacity							
			l/min	0	20	50	75	100	125	150
Single Phase	[kW]	[HP]	m³/h	0	1,2	3	4,5	6	7,5	9
			H=Total manometric head in meters							
OPTIMA M	0,25	0,33		7,6	7,0	6,3	5,4	4,3	3,1	1,5

PUMP

**OPTIMA MA**  
(With float switch)

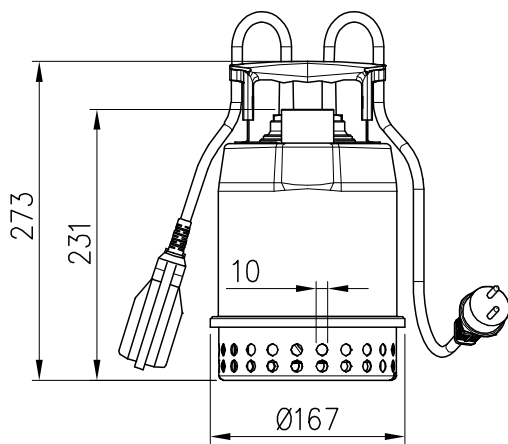

**OPTIMA MS**  
(With magnetic switch)

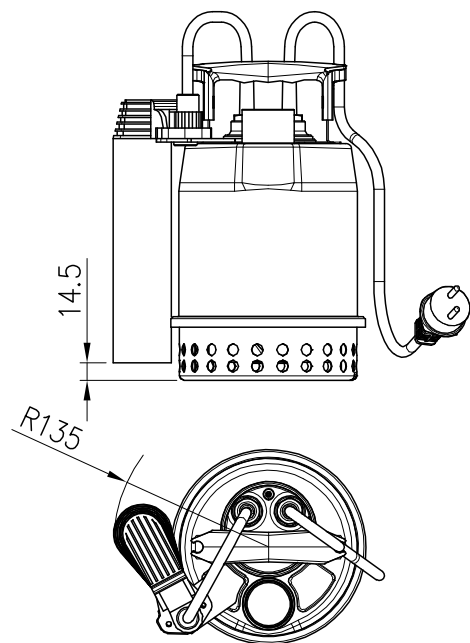

Pump Type	Weight [kgf]
OPTIMA M	4,2
OPTIMA MA	4,4
OPTIMA MS	4,6

PACKING

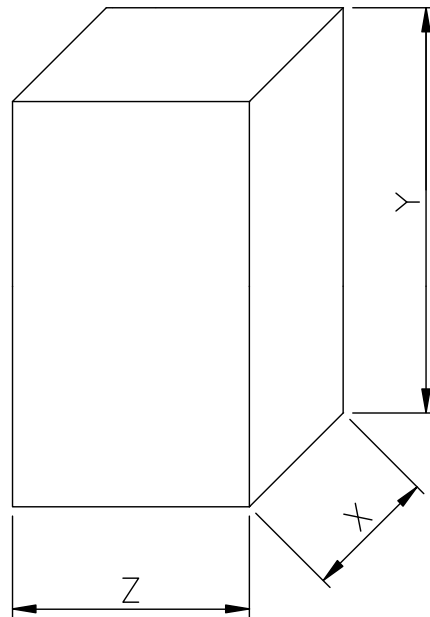

Pump Type	Dimensions [mm]			Weight [kgf]
	X	Y	Z	
OPTIMA M	180	330	220	4,7
OPTIMA MA				4,9
OPTIMA MS				5,1

**INSTALLATION**

**OPTIMA MA  
(With float switch)**

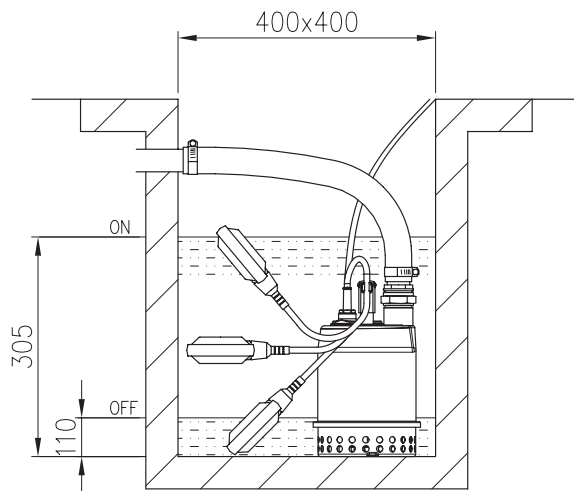

**OPTIMA MS  
(With magnetic switch)**

