

## DRAINAGE DRENO

submersible pump for drainage



clean water



muddy water

**Max Head** 8 - 21m

**Max Flow** 5 - 34m<sup>3</sup>/h

**Motor Power** 0.15 - 1.5Kw

**Discharge size** G1F/G2F



### KEY ADVANTAGES OF A DRENO PUMP

#### APPLICATION

Dreno are submersible drainage pumps with their 5 mm spherical clearance they are the ideal solution to pump water from basements cellars sumps and collection tanks. Also suitable for pumping discharge from hand basins, showers and washing machines, for flood relief and water removal from water courses or reservoirs.

#### INSTALLATION

Permanent or transportable. Model with float switch control for automatic pump operation, depending on liquid level in the sump.

#### MATERIALS

Double seals, lip seals and reinforced carbon ceramic mechanical seal. Motor casing in stainless steel, 304 stainless steel open impeller, pump body in cast iron, 420 stainless steel shaft

#### PUMPED LIQUID

Clear water and drainage water containing soft solids up to 5 mm spherical clearance. Max. liquid temperature: 35°C.

#### MOTOR

Fully submersible, pressure tight electric motor. Stainless steel motor- and pump housing. Insulation class F. Motor protection IP 68. Thermal sensors imbedded in the motor winding.

#### FEATURES

Power cable: 10 m neoprene.  
Immersion depth of 10 m.

# CHARACTERISTIC CURVES AND PERFORMANCE DATA

50 Hz

DRAINAGE  
**DRENO**

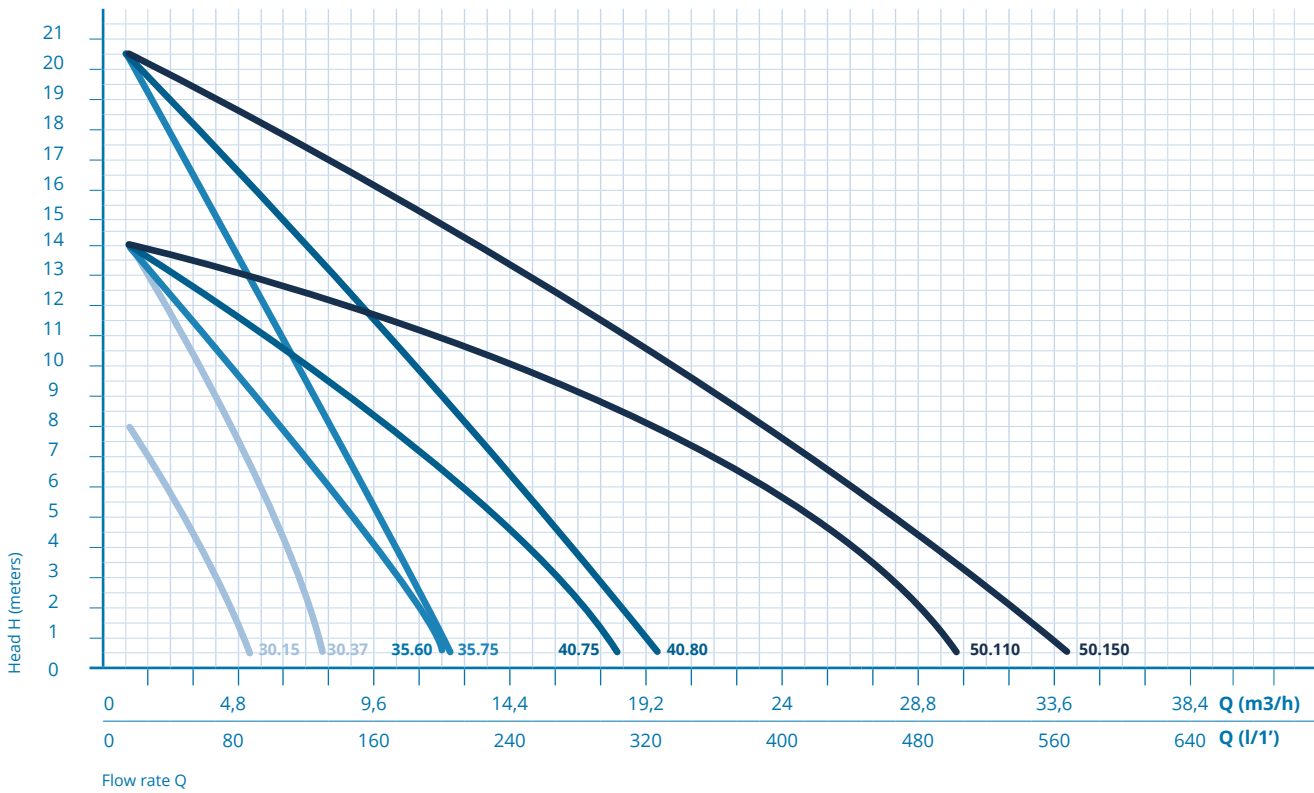

TYPE	POWER kW	I(A)		PORT DN	Q m³/h l/min	0	1,5	3	4,5	6	7,5	10,5	12	15	18	21	24	27	30
		1x230	3x400			0	25	50	75	100	125	175	200	250	300	350	400	450	500
R 30.15	0,15	2,9	1,1	1"		8	6,7	4,9	2,7										
R 30.37	0,37	3,4	1,3			14	12,6	10,6	8,1	5,2	1,7								
R 35.60	0,6	4,0	1,8	1"¼		14	12,9	11,7	10,4	9	7,5	4,2	2,4						
R 35.75	0,75	5,4	2,6			21	19	16,9	14,6	12,3	9,7	4,3	1,3						
R 40.75	0,75	5,0	2,6	1"½	H- meters	14	13,3	12,7	11,9	11,1	10,2	8,1	6,9	4,4	1,5				
R 40.80	0,8	7,8	3,0			21	19,6	18,2	16,7	15,2	13,7	10,6	9	5,7	2,3				
R 50.110	1,1	8,5	3,0	2"		14	13,6	13,4	13,2	12,9	12,5	11,7	11,3	10,2	8,9	7,4	5,7	3,8	1,7
R 50.150	1,5	8,8	4,0			21	19,9	19,2	18,5	17,7	17	15,4	14,6	13	11,3	9,5	7,7	5,9	3,9

## COMPONENTS AND MATERIALS

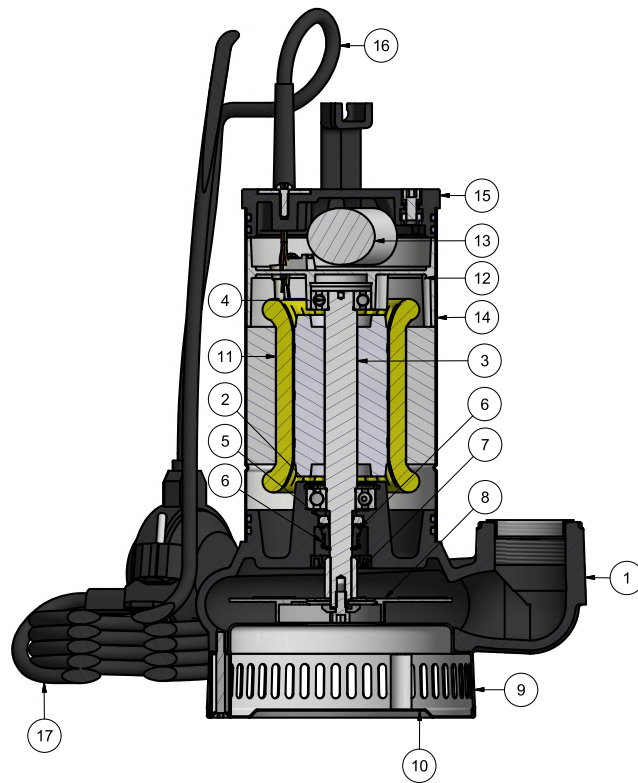

POS	COMPONENT	MATERIALS
1	Body Dreno Pump	Cast Iron
2	Bearing	Steel
3	Rotor / Shaft	Steel and Aluminium / Stainless Steel
4	Bearing	Steel
5	Mechanical Seal Fixe	Nitrile Rubber / Ceramics
6	Mechanical Seal Mobile	Graphite Steel
7	Lip Seals	Nitrile Rubber
8	Impeller Pump Dreno	Stainless Steel
9	Body Filter Aspiration	Stainless Steel
10	Aspiration Filter Cover	Stainless Steel
11	Stator	-
12	Top Engine Support	Aluminium
13	Capacitor	-
14	Motor Casing	Stainless Steel
15	Pump Cover	Neoprene / Plastic
16	Float	Neoprene

## DIMENSIONS AND WEIGHT

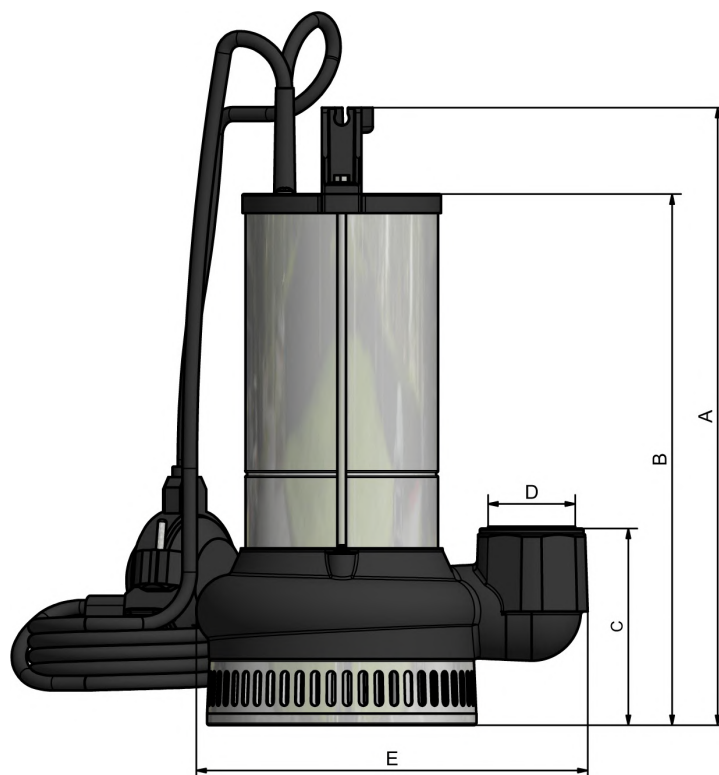

TYPE	DIMENSIONS (mm)					WEIGHT Kg	PALETTE Un
	A	B	C	ØD	E		
R 30.15	289,5	239,5	91	1"	136	8,9	60
R 30.37	299,5	249,5	—	—	—	9,1	
R 35.60	332	283	99	1¼"	218	11,0	
R 35.75	342	293	—	—	—	11,5	
R 40.75	347	298	114	1½"	227	12,0	
R 40.80	357	308	—	—	—	12,5	
R 50.110	400	352	125	2"	258	16,0	
R 50.150	410	362	—	—	—	17,0	