

**Customer**

## Technical data

### Submersible drainage pump Drain TS 40/10-A (1~230 V)

Project name

Project ID

Installation location

Customer pos.no

Date 2020-04-09

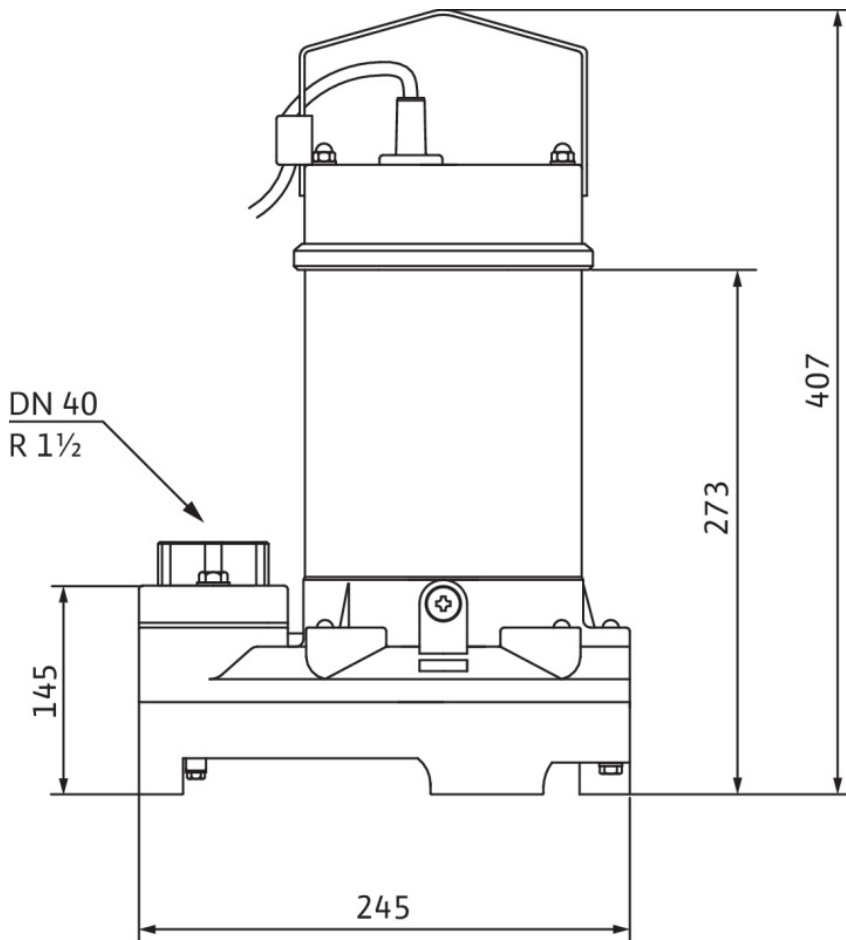
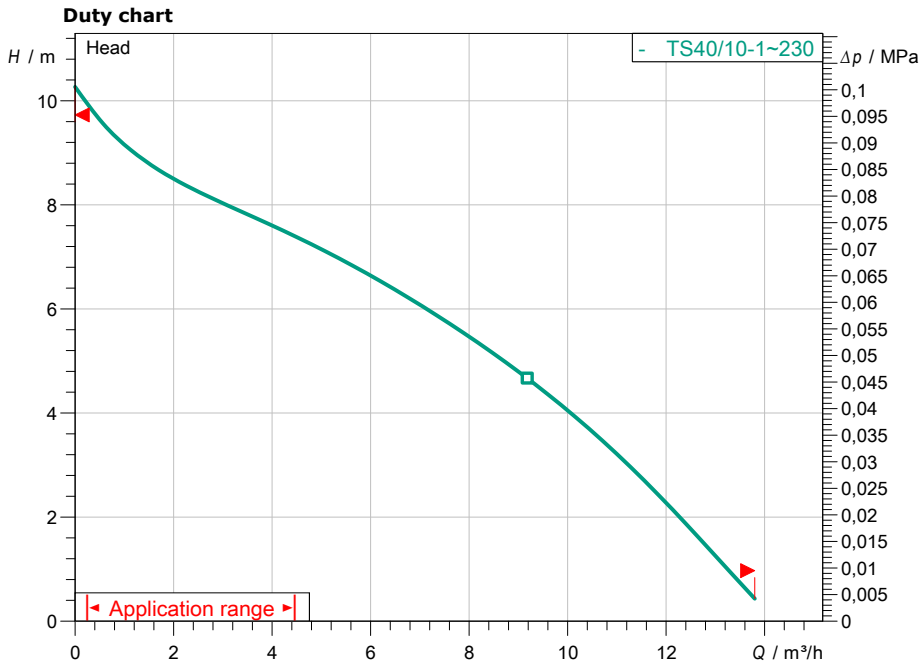

**Requested data**

Flow	
Head	
Media	Water 100 %
Fluid temperature	20,00 °C
Density	998,30 kg/m <sup>3</sup>
Kin. viscosity	1,00 mm <sup>2</sup> /s

**Hydraulic data (Duty point)**

Flow	
Head	
Power input P1	
Total efficiency	

**Product data**

Submersible drainage pump	
Drain TS 40/10-A (1~230 V)	
Max. operating pressure	0,2 MPa
Fluid temperature	3 °C ... + 35 °C
Maximum submergence depth	7 m
Free ball passage	10 mm

**Motordata per Motor/Pump**

Type of motor	Submersible motor – air-
Mains connection	1~ 230 V / 50 Hz
Permitted voltage tolerance	±10 %
Nominal speed	2900 1/min
Rated power P2	0,40 kW
Power input P1	0,48 kW
Rated current	2,20 A
Activation type	Direct online (DOL)
Degree of protection	IP68
Float switch	yes
Motor protection	
Insulation class	B
Operating mode (immersed)	S1
Operating mode (non-immersed)	-
Max. operating rate	50 1/h

**Cable**

Length of connecting cable	10 m
Cable type	H07RN-F
Cable cross section	3G1
Type of connecting cable	Detachable
Mains plug	

**Fitting dimensions**

Pipe connection on the suction side	-
Pipe connection on the pressure side	Rp 1 1/2,

**Materials**

Pump housing	PP-GF40
Impeller	PP-GF30
Shaft	1.4404
Sealing on pump side	QQPGG
Sealing on motor side	QQPGG
Gasket material	NBR
Motor housing	1.4301

**Information for order placements**

Weight approx.	14,2 kg
Item number	2063926