

Field of application

The backwash filters Ratio DFR / FR are designed for potable water installations. Use the HOT- types for temperatures up to 80°C.

Design

Backwash filter with filter insert made of non-rusting stainless steel material, mesh width 90 - 125 µm.

The Ratio DFR model also includes the following:

pressure reducing valve, factory-set to an outlet pressure of 4 bar, external adjustment knob for individual pressure setting, adjustment range 1,5 to 6 bar, outlet pressure indicator 0-10 bar.

Service pressure: min. 2 bar, max. 16 bar

Medium: potable water

Service temperature: max. 30°C (HOT up to 80°C max.)

Flow rate Ratio FR / FR HOT:

Nominal size	DN 15	DN 20	DN 25
Connection size	R ½"	R ¾"	R 1"
Δp 0,2 bar	2,0 m³/h	2,3 m³/h	3,0 m³/h
Δp 0,5 bar	3,4 m³/h	4,4 m³/h	5,2 m³/h

Flow rate Ratio DFR / DFR HOT:

Nominal size	DN 15	DN 20	DN 25
Connection size	R ½"	R ¾"	R 1"
Δp 1,1 bar	1,3 m³/h	2,3 m³/h	2,3 m³/h

All materials used are state-of-the-art. All synthetic and elastomeric components getting into contact with potable water are approved by the German Public Health Office (KTW recommendations).

Installation

When installing, make sure to observe the correct direction of flow! An arrow on the flange body indicates the direction of flow. Install the filter with the main axis in vertical position.

For adjusting the pressure reducer's outlet pressure indicator, turn it by 360° in any direction until readily readable.

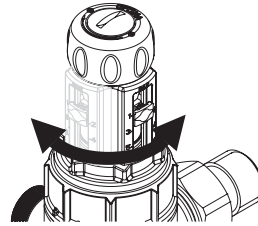

Maintenance

It is highly recommended to service the filter by backwashing every six months at the latest.

- Collect the backwash water with a suitable container. The drain pipe or container shall be able to collect the drain volume.
- Turn the ball valve by 90° downwards (fig. 2) until reaching the vertical position (open).
- To clean the filter, rotate the ribbed lower part several times to the left and to the right (fig. 3).
- Turn the ball valve by 90° to the left (fig. 1) until reaching the horizontal position (close).
- Even during backwashing, the device continues to supply filtered water into the potable water system.

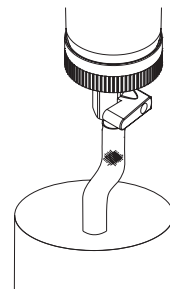

pic. 1

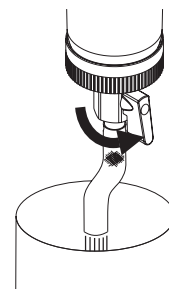

pic. 2

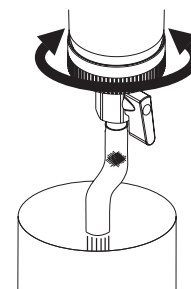

pic. 3

Outlet pressure setting

The Ratio DFR's pressure reducing valve is factory set to 4 bar and can be adjusted in a range from 1 to 6 bar as follows:

- Ensure that the inlet pressure is at least one bar higher than the desired outlet pressure.
- Unfasten the locking screw to unlock (4).
- To reduce the pressure: turn the adjustment knob in the direction of the minus symbol (-).
- Open a nearby draw-off point and close it again.

- To increase the pressure: turn the adjustment knob in the direction of the plus symbol (+) (5) and observe the outlet pressure manometer.
- When the desired outlet pressure is reached, tighten the locking screw again (6).

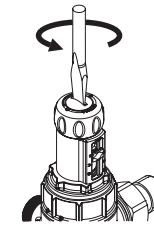

pic. 4

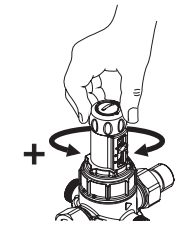

pic. 5

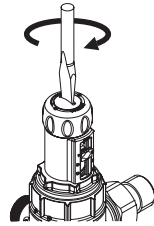

pic. 6

Retrofitting with a pressure reducer

The Ratio FR can be easily transformed into a DFR.

Proceed as follows:

- Close the shut-off valves upstream and downstream of the filter.
- Unfasten the plug by means of the key.
- Remove the plug from the filter.
- Insert the pressure reducer cartridge.
- Screw tight the cartridge.
- Open the shut-off valves upstream and downstream of the filter.

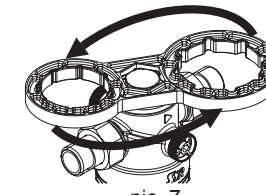

pic. 7

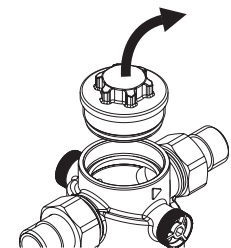

pic. 8

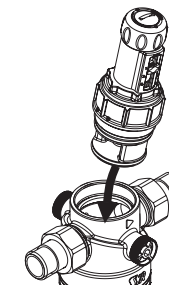

pic. 9

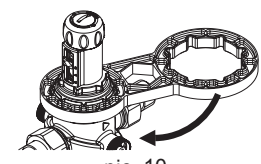

pic. 10

Troubleshooting/Repair

What to do, when the outlet pressure rises?

The pressure increase is probably due to a downstream unvented water heater and has not been held off by the check valve upstream of the water heater. With the water heater's heating function being disconnected, this effect shall no longer occur once hot water has been drawn off. If this effect does not occur again, the check valve in the water heater's safety group needs to be serviced or replaced. Should this effect still occur with the heating function being disconnected, the problem is due to a worn pressure reducer cartridge. In this case, exchange the cartridge as follows:

- Close the shut-off valves upstream and downstream of the filter.
- Relieve the pressure by means of the ball valve.
- Remove the pressure reducer cartridge and replace it.
- Open the shut-off valves again.

In case of dirt accumulation, clean the pressure reducer cartridge as follows: close the shut-off valves upstream and downstream of the pressure reducing valve, unfasten the screw cap and remove the cartridge, clean the cartridge **ONLY WITH CLEAR COLD WATER**. Assembly in reversed order.

Only qualified installers are authorised to install and service the device. Observe the maintenance instructions! Do not clean synthetic parts with solvent-based detergents. Do not install filters in areas, which are exposed to UV-radiation (sunlight) or solvent vapours. Protect the filter against frost. When submitted to hard shocks, the synthetic part concerned shall be exchanged (even when damages are not visible). Avoid strong water hammers, caused for instance by downstream solenoid valves (danger of burst). The packaging serves as protection during transport. Should it be severely damaged, do not install the device!

Spare parts

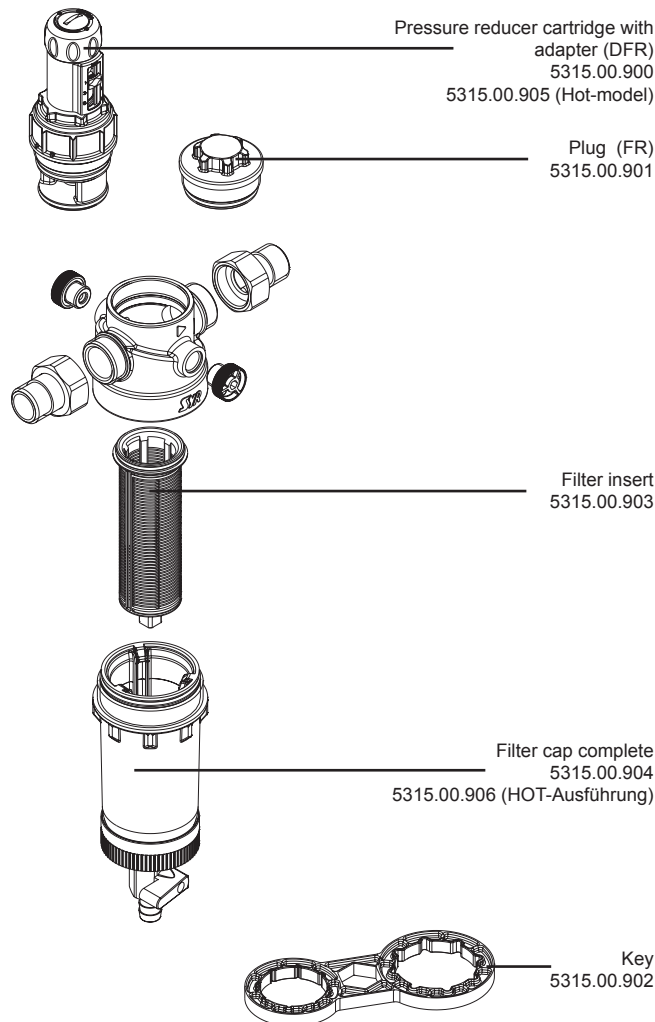

SYR® **ARMATUREN**
Made in Germany

Instructions for use

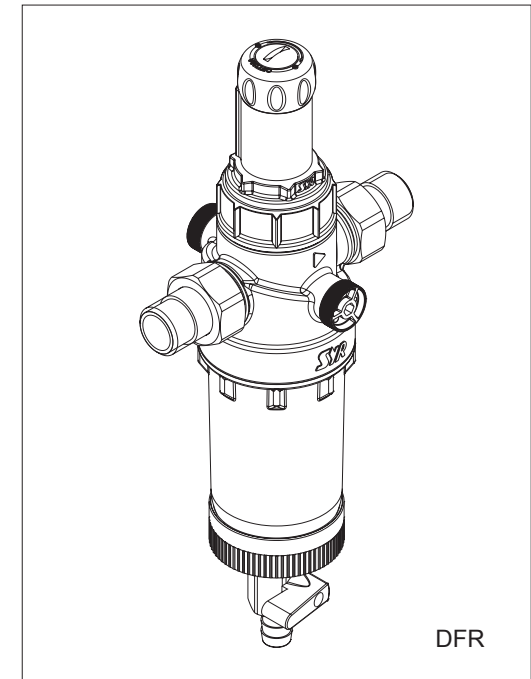

RATIO DFR / DFR HOT
Backwash filter with pressure reducing valve

RATIO FR / FR HOT
Backwash filter

Hans Sasserath GmbH & Co. KG
Tel.: +49 2161 6105-0 Fax: +49 2161 6105-20
Mühlenstrasse 62 D-41352 Korschenbroich
eMail info@SYR.de www.SYR.de