

Qty.	Description
------	-------------

1	SBA 3-45 A
---	------------



Note! Product picture may differ from actual product

Product No.: [97896290](#)

Grundfos SBA 3-45 A is an all-in-one submersible booster designed for pumping clean water for domestic use. The SBA is built on the proven SB platform and comes with an integrated control unit. This eliminates the need for an external pump controller in the house. It is silent when submerged and therefore a noiseless alternative to surface-mounted pumps. The pump is built from high quality composite and stainless steel materials that are resistant to corrosion.

The SBA 3-45 A is equipped with a 15 m supply cable, and the maximum installation depth is 10 m below the water level, with a liquid temperature ranging from 0 °C to 40 °C.

The pump starts automatically when the pipe pressure falls below 2.2 bar.

The SBA 3-45 A is ideal for operation in a well or ground tanks, as it easily prevents solid particles from entering the pump. The maximum particle size is 1 mm.

The pump features a float switch, which promises the user a convenient experience with automatic start/stop operation of the pump and provides dry running protection.

Qty. Description

The single-phase model is effectively protected against any accidental overload by built-in thermal protection.

The pump has built-in thermal protection, which immediately stops the pump if it overheats. Having cooled down, the pump automatically restarts when it reaches a normal temperature.

Liquid:

Pumped liquid: Water
 Liquid temperature range: 0 .. 40 °C
 Selected liquid temperature: 20 °C
 Density: 998.2 kg/m³

Technical:

Rated flow: 2.83 m³/h
 Rated head: 30.1 m
 Max. Particle: 1 mm
 Curve tolerance: ISO9906:2012 3B
 Return valve: YES
 Adjustable start pressure: N
 Start pressure: 2.2 bar
 Rated driver speed: 2800 rpm

Materials:

Pump housing: Composite
 Impeller: Composite

Installation:

Range of ambient temperature: -10 .. 50 °C
 Type of inlet connection: STRAINER
 Pump outlet: G 1"
 Maximum installation depth: 10 m

Electrical data:

Power input P1: 1.05 kW
 Rated power - P2: 0.62 kW
 Mains frequency: 50 Hz
 Rated voltage: 1 x 220-240 V
 Rated current: 4.8 A
 Starting current: 12 A
 Cos phi: 0.94
 Capacitor size - run: 13 µF/450 V
 Enclosure class (IEC 34-5): IP68
 Insulation class (IEC 85): F
 Built-in motor protection: YES
 Length of cable: 15 m
 Cable type: H07RN-F 3G1
 Type of cable plug: SCHUKO

Others:

Net weight: 9.69 kg
 Gross weight: 10.4 kg
 Shipping volume: 0.022 m³
 Danish VVS No.: 391367045
 Swedish RSK No.: 5850421
 Finnish LVI No.: 4822546
 Norwegian NRF no.: 9041859
 Approvals: CE,VDE,WEEE
 Country of origin: FR



Company name:

Created by:

Phone:

Date:

14/04/2020

Qty.	Description
	Custom tariff no.: 84137029

Description	Value
General information:	
Product name:	SBA 3-45 A
Product No:	97896290
EAN number:	5710626001750
	5710626001750
Price:	633,00 EUR
Technical:	
Rated flow:	2.83 m ³ /h
Rated head:	30.1 m
Maximum head:	45 m
Impellers:	4
Max. Particle:	1 mm
Curve tolerance:	ISO9906:2012 3B
Return valve:	YES
Adjustable start pressure:	N
Start pressure:	2.2 bar
Rated driver speed:	2800 rpm
Materials:	
Pump housing:	Composite
Impeller:	Composite
Installation:	
Range of ambient temperature:	-10 .. 50 °C
Type of inlet connection:	STRAINER
Pump outlet:	G 1"
Maximum installation depth:	10 m
Liquid:	
Pumped liquid:	Water
Liquid temperature range:	0 .. 40 °C
Selected liquid temperature:	20 °C
Density:	998.2 kg/m ³
pH-value range:	4-9
Electrical data:	
Power input P1:	1.05 kW
Rated power - P2:	0.62 kW
Mains frequency:	50 Hz
Rated voltage:	1 x 220-240 V
Rated current:	4.8 A
Starting current:	12 A
Cos phi:	0.94
Capacitor size - run:	13 µF/450 V
Enclosure class (IEC 34-5):	IP68
Insulation class (IEC 85):	F
Built-in motor protection:	YES
Length of cable:	15 m
Cable type:	H07RN-F 3G1
Type of cable plug:	SCHUKO
Controls:	
Flow switch:	yes
Others:	
Net weight:	9.69 kg
Gross weight:	10.4 kg
Shipping volume:	0.022 m ³
Danish VVS No.:	391367045
Swedish RSK No.:	5850421
Finnish LVI No.:	4822546
Norwegian NRF no.:	9041859
Approvals:	CE,VDE,WEEE
Country of origin:	FR

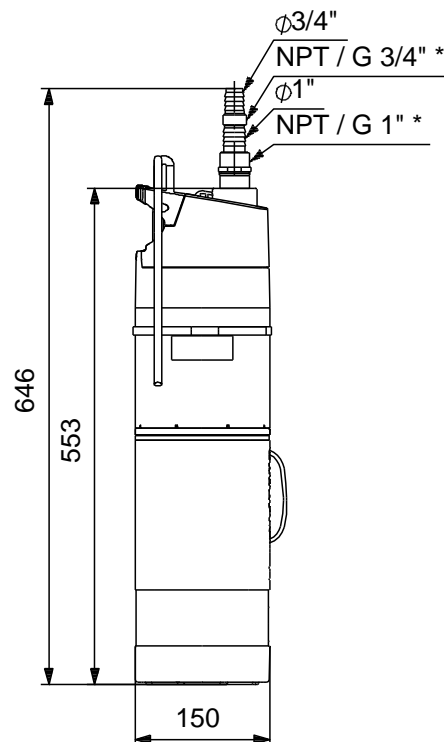
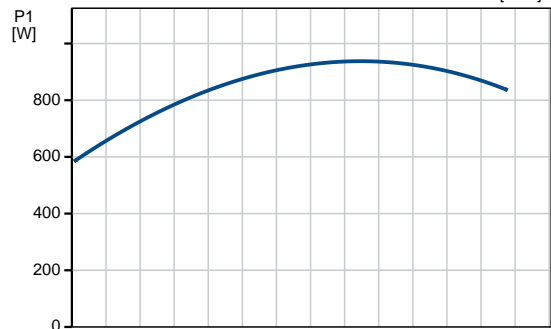
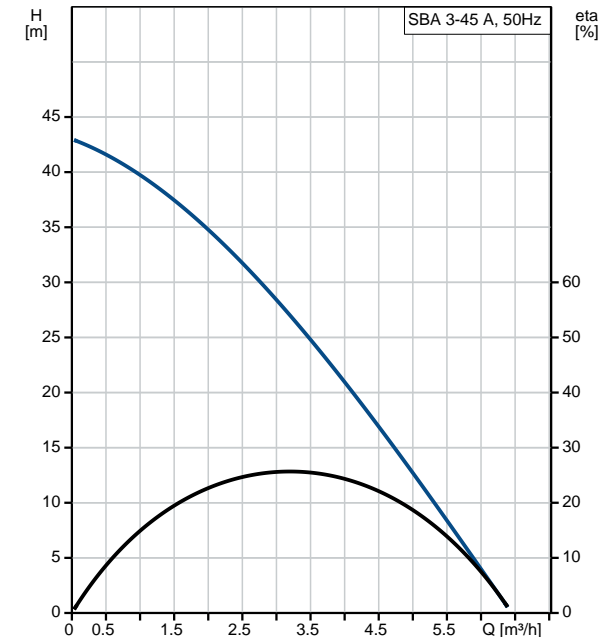



Company name:

Created by:

Phone:

Date:

14/04/2020

Description

Value

Custom tariff no.:

84137029